

මගේ අංකය : TF/AD/04/45  
2026.05.22 දින.

**මේස සහ පුටු මිලදී ගැනීම සඳහා මිල ගණන් කැඳවීම**

ටවර් හෝල් රහහල පදනමේ පරිගණක විද්‍යාගාරය හා කාර්යාලය සඳහා මේස, පුටු මිලදී ගැනීම සඳහා මිල ගණන් කැඳවීමට පාලනාධිකාරිය තීරණය කර ඇත. ඊට අදාළ ලංසු ලියවිලි හා කොන්දේසි ටවර් හෝල් රහහල පදනමේ වෙබ් අඩවියේ ([www.towerhall.lk](http://www.towerhall.lk)) පළකර ඇති අතර එම ලංසු ලියවිලි හා කොන්දේසි භාගත කර හෝ ටවර් හෝල් රහහල පදනම ප්‍රධාන කාර්යාලයෙන් ලබාගෙන මිල ගණන් ඉදිරිපත් කල හැක.

ඒ අනුව මේස, පුටු මිලදී ගැනීම සඳහා මිල ගණන් නියමිත ආකෘතියෙහි සඳහන් කර මුද්‍රා තැබූ මිල ගණන් වර්ෂ 2026.06.11 දින ප.ව.2.00 ට පෙර “සභාපති ,ප්‍රසම්පාදන කමිටුව,ටවර් හෝල් රහහල පදනම, සවිසිරිපාය, අංක 123, විජේරාම මාවත, කොළඹ -07 ” යන ලිපිනයේ පිහිටි ටවර් හෝල් රහහල පදනම ප්‍රධාන කාර්යාලයේ තබා ඇති ටෙන්ඩර් බහාලනයට අතින් ගෙනැවිත් හෝ එදින ප.ව.2.00 ට පෙර ලැබෙන සේ ලියාපදිංචි තැපෑලෙන් එවන මෙන් කාරුණිකව ඉල්ලා සිටිමි. මිල ගණන් ලබාගැනීම අවසන් වූ සෑහින් මිල ගණන් විවෘත කරනු ලබයි. ප්‍රමාද වී ලැබෙන මිල ගණන් ප්‍රතික්ෂේප කරනු ලබන අතර ලංසු විවෘත කරන අවස්ථාව සඳහා ලංසුකරුට හෝ ඔහුගේ බලයලත් අයෙකුට සහභාගී විය හැකිය.

මිල ගණන් බහාලන කවරයේ ඉහළ වම් කෙලවරේ “මේස,පුටු සඳහා මිල ගණන් ” ලෙස සඳහන් කරන ලෙස වැඩිදුරටත් කාරුණිකව දන්වා සිටිමි.

නිපුණ දිසානායක  
අධ්‍යක්ෂ(පාලන හා සංවර්ධන)  
දු.ක. : 0112682324  
ෆැක්ස් අංකය : 0112678517  
විද්‍යුත් තැපෑල : towersl@slt.net.lk





# **Procurement of Goods**

**Under**

## **National Shopping Procedures**

Invitation of Quotations

For

### **Supplying and Delivering of Furniture for Tower Hall Theatre Foundation.**

Contract No:

**TF/AD/04/45/Furniture/2026**



**Tower Hall Theatre Foundation**

## Section I. Instructions to Vendors (ITV)

<b>A: General</b>	
1. Scope of Bid	1.1 The Purchaser named in the Data Sheet invites you to submit a quotation for the supply of Goods as specified in Section III Schedule of Requirements. Upon receipt of this invitation, you are requested to acknowledge the receipt of this invitation and your intention to submit a quotation. The Purchaser may not consider you for inviting quotations in the future, if you failed to acknowledge the receipt of this invitation or not submitting a quotation after expressing the intention as above.
<b>B: Contents of Documents</b>	
2. Contents of Documents	<p>The documents consist of the Sections indicated below.</p> <ul style="list-style-type: none"> <li>• Section I. Instructions to Vendors (ITV)</li> <li>• Section II. Data sheet</li> <li>• Section III. Schedule of Requirements</li> <li>• Section IV. Technical Specifications &amp; Compliance with Specifications</li> <li>• Section V. Quotation submission Form(s)</li> <li>• Bid-Securing Declaration</li> <li>• Non-Collusion Affidavit</li> </ul>
<b>C: Preparation of Quotation</b>	
3. Documents Comprising your Quotation	<p>The Quotation shall comprise the following:</p> <ol style="list-style-type: none"> <li>(a) Quotation Submission Form and the Price Schedules;</li> <li>(b) Technical Specifications &amp; Compliance with Specifications</li> <li>(c) Bid Guarantee &amp; Non-Collusion Affidavit</li> </ol>
4. Quotation Submission Form and Price Schedules	<p>The vendor shall submit the Quotation Submission Form using the form furnished in Section V. This form must be completed without any alterations to its format, and no substitutes shall be accepted. All blank spaces shall be filled in with the information requested.</p> <p>Alternative offers shall not be considered. The vendors are advised not to quote different options for the same item but furnish the most competitive among the options available to the bidder.</p>
5. Prices and Discounts	<p>Unless specifically stated in Data Sheet, all items must be priced separately in the Price Schedules.</p> <p>The price to be quoted in the Quotation Submission Form shall be the total price of the Quotation, including any discounts offered.</p>

	<p>The applicable VAT shall be indicated separately.</p> <p>Prices quoted by the vendor shall be fixed during the vendor's performance of the Contract and not subject to variation on any account. A Quotation submitted with an adjustable price shall be treated as non-responsive and may be rejected.</p>
6. Currency	6.1 The vendors shall quote only in Sri Lanka Rupees.
7. Documents to Establish the Conformity of the Goods	<p>The vendor shall furnish as part of its quotation the documentary evidence that the Goods conform to the technical specifications and standards specified in Section IV, "Technical Specifications &amp; Compliance with Specifications".</p> <p>The documentary evidence may be in the form of literature, drawings or data, and shall consist of a detailed item by item description of the essential technical and performance characteristics of the Goods, demonstrating substantial responsiveness of the Goods to the technical specifications, and if applicable, a statement of deviations and exceptions to the provisions of the Technical Specifications given.</p> <p>If stated in the Data Sheet the vendor shall submit a certificate from the manufacturer to demonstrate that it has been duly authorized by the manufacturer or producer of the Goods to supply these Goods in Sri Lanka.</p>
8. Period of Validity of quotation	8.1 Quotations shall remain valid for the period of Fourty Nine (49) days after the quotation submission deadline date.
9. Format and Signing of Quotation	9.1 The quotation shall be typed or written in indelible ink and shall be signed by a person duly authorized to sign on behalf of the vendor.
<b>D: Submission and Opening of Quotation</b>	
10. Submission of Quotation	<p>Vendors may submit their quotations by registered post or by hand in sealed envelopes addressed to the Purchaser bear the specific identification of "<b>Supplying and Delivering of Furniture for Tower Hall Theatre Foundation</b>".</p> <p>If the quotation is not sealed and marked as required, the Purchaser will assume no responsibility for the misplacement or premature opening of the quotation.</p>
11. Deadline for Submission of Quotation	11.1 Quotation must be received by the Purchaser at the address set out in Section II, "Data Sheet", and no later than the date and time as specified in the Data Sheet.
12. Late Quotation	12.1 The Purchaser shall reject any quotation that arrives after the deadline for submission of quotations, in accordance with IIV Clause 11.1 above.

13. Opening of Quotations	<p>The Purchaser shall conduct the opening of quotation in public at the address, date and time specified in the Data sheet.</p> <p>A representative of the bidders may be present and mark its attendance.</p>
<b>E: Evaluation and Comparison of Quotation</b>	
14. Clarifications	<p>To assist in the examination, evaluation and comparison of the quotations, the Purchaser may, at its discretion, ask any vendor for a clarification of its quotation. Any clarification submitted by a vendor in respect to its quotation which is not in response to a request by the Purchaser shall not be considered.</p> <p>The Purchaser's request for clarification and the response shall be in writing.</p>
15. Responsiveness of Quotations	<p>The Purchaser will determine the responsiveness of the quotation to the documents based on the contents of the quotation received.</p> <p style="text-align: center;">If a quotation is evaluated as not substantially responsive to the documents issued, it may be rejected by the Purchaser.</p>
16. Evaluation of quotation	<p>The Purchaser shall evaluate each quotation that has been determined, to be substantially responsive.</p> <p style="text-align: center;">To evaluate a quotation, the Purchaser may consider the following:</p> <ul style="list-style-type: none"> <li>(a) the Price as quoted;</li> <li>(b) price adjustment for correction of arithmetical errors;</li> <li>(a) Price adjustment due to discounts offered.</li> </ul> <p>16.3 The Purchaser's evaluation of a quotation may require the consideration of other factors, in addition to the Price quoted if stated in Section II, Data Sheet. These factors may be related to the characteristics, performance, and terms and conditions of purchase of the Goods.</p>
17. Purchaser's Right to Accept any Quotation, and to Reject any or all Quotations	17.1 The Purchaser reserves the right to accept or reject any quotation, and to annul the process and reject all quotations at any time prior to acceptance, without thereby incurring any liability to bidders.

**F: Award of Contract**

<b>F: Award of Contract</b>	
18. Acceptance of the Quotation	18.1 The Purchaser will accept the quotation of the vendor whose offer has been determined to be the lowest evaluated bid and is substantially responsive to the documents issued.
19. Notification of acceptance	19.1 Prior to the expiration of the period of validity of quotation, the Purchaser will notify the successful vendor, in writing, that its quotation has been accepted.

## Section II: Data Sheet

ITV Clause Reference	
1.1	<p>The Purchaser is: <b>Tower Hall Theatre Foundation</b>  Address: <b>“Sausiripaya”</b>  <b>No. 123, Wijerama Mawatha,</b>  <b>Colombo 07.</b></p> <p><b>The name and identification a number of the contract.0112-682324</b></p> <p><b>Procurement Name: Supplying and Delivering of Furniture for  Tower Hall Theatre Foundation .</b></p> <p><b>Procurement NO: TFAD/04/45/Furniture/2026</b></p>
5.1	Bidder can quote one or more items from section III
11.1	<p>Address for submission of Quotations is  <b>Chairman,</b>  <b>Tower Hall Theatre Foundation</b>  <b>“Sausiripaya”</b>  <b>No. 123, Wijerama Mawatha,</b>  <b>Colombo 07.</b></p> <p>Telephone No. :<b>011-2682324</b>      Fax No.: <b>0112-678517</b></p> <p>Deadline for submission of quotation: <b>11.06.2026 Time:14.00 hours</b></p>
13	<p>The quotation shall be opened at the following address:  <b>Tower Hall Theatre Foundation</b>  <b>“Sausiripaya”</b>  <b>No. 123, Wijerama Mawatha,</b>  <b>Colombo 07.</b></p>
16 <sup>1</sup>	<p>Other factors that will be considered for evaluation are (List and describe the methodology):</p> <ol style="list-style-type: none"> <li><b>1.</b> Alternative offers, Options will be caused to reject all bids.</li> <li><b>2.</b> Bidder should provide necessary brochures with specification sheets of equipment</li> <li><b>3.</b> Usage of latest available technology more applicable.</li> </ol>

### Section III: Schedule of Requirements

Item No.	Description	No's of units	Address of final destination	Transportation Any other services.	Delivery Date	
					Latest Delivery Date	Bidder's offered Delivery date (To be provided by the bidder.)
01	High Back Chair (Category 1)	02	<b>As per the Delivery Schedule</b>	<b>Required</b>	<b>Within 21 days of purchase order</b>	
02	High Back Chair (Category 2)	11				
03	Low Back Chair	40				
04	Visitors Chair (Category 1)	03				
05	Visitors Chair (Category 2)	28				
06	Computer Chair	15				
07	Computer Table	15				

Signature : .....

Contact No : .....

Date : .....

Official Seal :

### Section (IV) : Technical Specification

	Description	Requirement	Quantity	Response		Remarks
				Yes	No	
		<i>Tower Hall Theatre Foundation</i>				
01.	High Back Chair (Category 1) (Refer Picture Details No 01)	Movable Arm rests Material - Genuine Leather Color – Black	02			
02.	High Back Chair (Category 2) (Refer Picture No 02)	Movable Arm rests Color – Black Material - Rexene	11			
03.	Low Back Chair (Refer Picture No 03)	Movable Arm rests Color – Black Material – PVC cloth finish	40			

04.	Visitors Chair (Category 1) (Refer Picture No 04)	Non-Movable Arm rests Color – Black Material – PVC cloth finish	03			
05.	Visitors Chair (Category 2) (Refer Picture No 05)	Non-Movable Arm rests Color – Black Material – PVC cloth finish	28			
06.	Computer Chair (Refer Picture No 06)	Movable Arm rests Color – Blue Material – Upholstery: Fabric	15			
07.	Computer Table (Refer Picture No 07)	Length: 24” Width: 18” Height: 27.5” Color – Blue Material – Table top: Hard wearing MFC top Leg: Powder coated metal base with wheels	15			

Name of Bidder :.....

Signature of Bidder :.....

Date :.....

Official Seal

## Bid-Securing Declaration

*[Note: the purchaser is required to fill the information marked as “\*” and delete this note prior to selling of the bidding document]*

*[The Bidder shall fill in this form in accordance with the instructions indicated in brackets]*

Date: -----[insert date by bidder]

\*Name of contract --..... [insert name]

\*Contract Identification N<sup>o</sup>: ----[insert number]

\*Invitation for Bid No.: ----- - insert number]

\*To: ----- [insert the name of the Purchaser]

We, the undersigned, declare that:

1. We understand that, according to instructions to bidders (hereinafter “the ITB”), bids must be supported by a bid-securing declaration;
2. We accept that we shall be suspended from being eligible for contract award in any contract where bids have being invited by any of the Procuring Entity as defined in the Procurement Guidelines published by National Procurement Agency of Sri Lanka, for the period of time of *three years starting on the latest date set for closing of bids of this bid*, if we:
  - (a) Withdraw our Bid during the period of bid validity period specified; or
  - (b) do not accept the correction of errors in accordance with the Instructions to Bidders of the Bidding Documents; or
  - (c) having been notified of the acceptance of our Bid by you, during the period of bid validity,
    - (i) fail or refuse to execute the Contract Form, if required, or (ii) fail or refuse to furnish the performance security, in accordance with the ITB.
3. We understand this bid securing shall expire if we are not the successful bidder, upon the earlier of (i) our receipt of a copy of your notification to the Bidder that the bidder was unsuccessful; or (ii) twenty-eight days after the expiration of our bid.
4. We understand that if we are a JV, the Bid Securing Declaration must be in the name of the JV that submits the bid. If the JV has not been legally constituted at the time of bidding, the Bid Securing Declaration shall be in the names of all future partners as named in the letter of intent.

Signed *[insert signature(s) of authorized representative]* .....In the Capacity of *[insert title]*

Name *[insert printed or typed name]*.....

Duly authorized to sign the bid for and on behalf of *[insert authorizing entity]*.....

Dated on *[insert day]*..... day of *[insert month]*, *[insert year]*.....

# Quotation Submission Form

[The Vendor shall fill in this Form in accordance with the instructions indicated No alterations to its format shall be permitted and no substitutions will be accepted.]

Date:

To: .....

We, the undersigned, declare that:

- (a) We have examined and have no reservations to the document issued;
- (b) We offer to supply in conformity with the documents issued and in accordance with the Delivery Schedules specified in the Schedule of Requirements the following Goods .....;
- (c) The total price of our quotation including any discounts offered is: .....;
- (d) Our quotation shall be valid for the period of time specified in ITV Sub-Clause 8.1, from the date fixed for the quotation submission deadline in accordance with ITV Sub- Clause 11.1, and it shall remain binding upon us and may be accepted at any time before the expiration of that period;
- (e) We understand that this quotation, together with your written acceptance thereof included in your notification of award, shall constitute a binding contract between us.
- (f) We understand that you are not bound to accept the lowest evaluated quotation or any other quotation that you may receive.

Signed : .....

Name : .....

Date :.....

Official Seal : .....

# Non – Collusion Affidavit

The undersigned bidder or agent, hereby solemnly, sincerely, and truly declares and affirms/makes an oath that he/she not, nor has any other member, representative, representative, or agent of the firm, company, corporation, or partnership represented by him/her, entered into any combination, collusion, or agreement with any person relative to the price to be bid by anyone at such letting, nor to prevent any person from bidding, nor to induce anyone to refrain from bidding, and that this bid is made without reference to any other bid and without any agreement, understanding, or combination with any other person in reference to such bidding.

He/she further states that no person, firm, or corporation has received or will receive, directly or indirectly, any rebate, fee, gift, commission, or thing of value on account of such procurement.

The bidder accepts full responsibility for ensuring the absence of collusion and pledges to abide by fair and ethical competition for ensuring the absence of collusion and pledges to abide by fair and ethical competition practices throughout the procurement process.

I hereby affirm, under the penalties for perjury, that the facts and information contained in the foregoing bid for public works are true and correct.

The foregoing Affidavit having been duly read over and explained by me to the affirming above named and he/she having understood the contents there in and admitted to be correct, affirmed and set his/her signature here to before me )

Stamp Rs.50  
(Bidder  
should sign  
on the  
stamp)

On this ..... day of .....at.....

BEFORE ME,

JUSTICE OF THE PEACE/COMMISSIONER OF OATHS

## Price Schedule

1	2	3	4	5	6	7	8	9
Item No.	Description of Goods	Quantity	Unit price (Without VAT)	VAT 18%	Any other charges (please specify)	Total Price (Without VAT) (3x4)	Total Price (With VAT)	Warranty Period
01	High Back Chair (Category 1)	02						
02	High Back Chair (Category 2)	11						
03	Low Back Chair	40						
04	Visitors Chair (Category 1)	03						
05	Visitors Chair (Category 2)	28						
06	Computer Chair	15						
07	Computer Table	15						

Name of Bidder : .....

Signature of Bidder : .....

Date : .....

**Delivery Schedule**

	<b>Item</b>	<b>Quantity</b>	<b>Location to Deliver</b>
01	High Back Chair (Category 1)	02	<b>Tower Hall Theatre Foundation “Sausiripaya” No.123,Wijerama Mawatha, Colombo-07</b>
02	High Back Chair (Category 2)	11	
03	Low Back Chair	40	
04	Visitors Chair (Category 1)	03	
05	Visitors Chair (Category 2)	28	
06	Computer Chair	15	
07	Computer Table	15	

**1. High Back Chair (Category 1)  
(Picture 01)**



**2. High Back Chair (Category 2)  
(Picture 02)**



**3. Low Back Chair  
(Picture 03)**

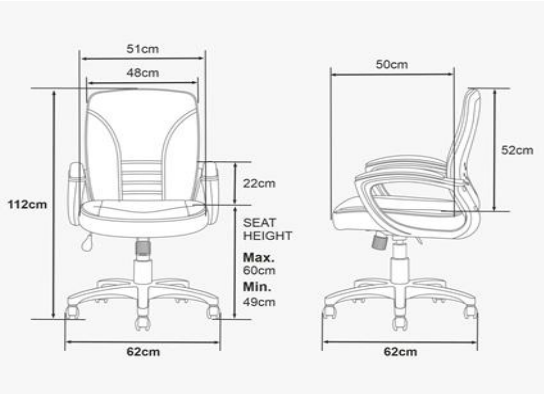

**4. Visitors Chair (Category 1)**  
**(Picture 04)**

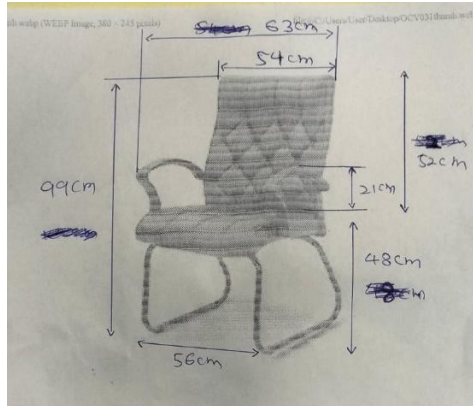

**5. Visitors Chair (Category 2)**  
**(Picture 05)**

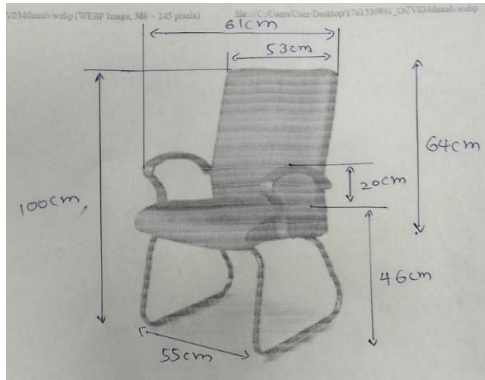

**6. Computer Chair**  
**(Picture 06)**

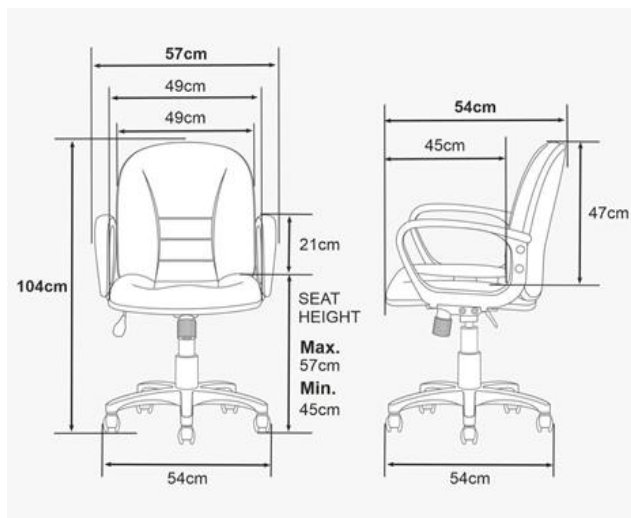

**7. Computer Table**

**(Picture 07)**



©QUR HOME FURNITURE (PVT) LTD



©QUR HOME FURNITURE (PVT) LTD